



# wt1650df

## Capitalize on opportunities in emerging markets

AMSC's Windtec Solutions include wind turbine designs that enable our partners to launch best-in-class wind turbines quickly, effectively and profitably. The wt1650df model, featuring proven doubly-fed drivetrain technology, has been one of the most reliable wind turbine technologies commissioned worldwide for the past 10 years.

### Proven over a decade

The wt1650df turbine is one of the world's most tested megawatt-scale models available today for wind power generation. It is backed by 10 years of reliable operation from thousands of wind turbines. The wt1650df is cost efficient to manufacture and utilizes state-of-the-art technologies, including an integrated drivetrain and the advanced wt82 rotor blade designed for self-manufacturing.

### High efficiency over the entire speed range

The wt1650df wind turbine is equipped with a doubly-fed, three-phase induction generator. The IGBT-based converter with advanced power electronics ensures that the generator works with high efficiency over the entire range of wind speeds.

### Unique pitch system maximizes generation and reliability

When wind speeds exceed rated speed, the advanced wt1650df pitch system quickly and smoothly adjusts the rotor blade angle to match the wind. If an overall pitch drive fault occurs, the integrated and patented SafetyLOCK™ system allows the blades to turn into a feathering position, even if electrical power is not available.

### Compliance with international grid codes

The wt1650df wind turbines fulfill the most demanding international grid code requirements and have low voltage ride-through (LVRT) capability.

### Real-time information with continuous monitoring and alarm handling

AMSC's advanced wtCMS™ condition monitoring system provides continuous monitoring of the key system components. This gives operators real-time information about the turbine status as well as detailed and comprehensive analysis tools to optimize maintenance activities. The fully integrated system allows intelligent measurement, turbine control interaction and the analysis of monitoring and performance data. In addition, wtSCADA™ remote operation and wtDataCenter™ analyzing packages are available to provide a harmonized control system with supervisory control and data acquisition to actively monitor, analyze and operate entire wind farms.

The 1.65 MW turbine is available in 50 Hz or 60 Hz, with 65 m, 70 m or 80 m hub heights.



- Customized wind turbine designs
- Reliable operation
- Excellent component supply chain and localization support
- Manufacturing documentation included for wt82 rotor blades

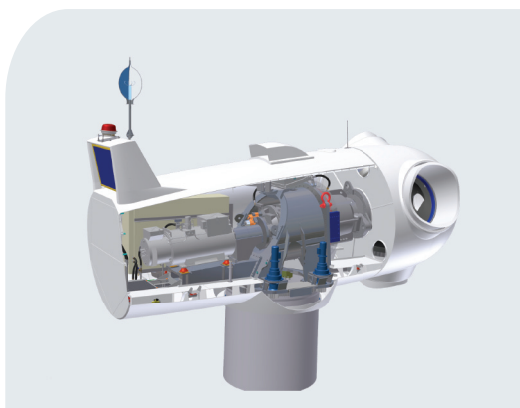

The wt1650df is fully designed by AMSC® and certified by Germanischer Lloyd.



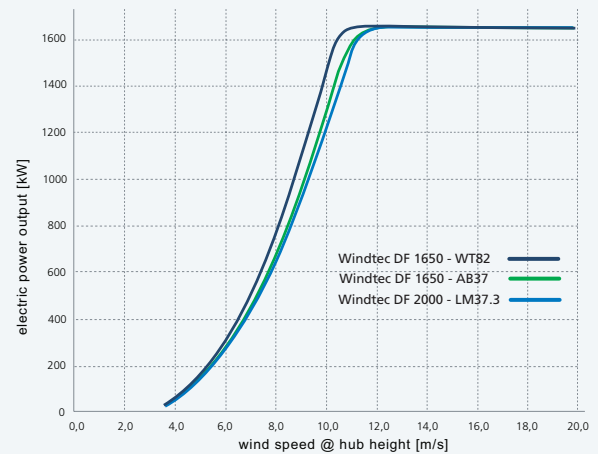
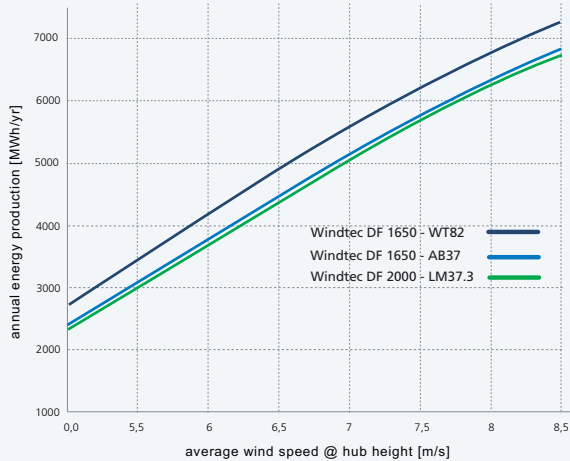

## GENERAL

	TC II	TC III
Type:	wt1650df	wt1650df
Grid frequency:	50 Hz / 60 Hz	50 Hz / 60 Hz
Tilt angle rotor axis:	4.5°	4.5°
Hub height:	70 m / 80 m	70 m / 80 m
Hub type / material:	cast iron	cast iron
Mainframe type:	cast iron	cast iron
Type of tower construction:	tubular steel tower	tubular steel tower
Rotor diameter:	77 m / 82 m	82 m
Lightning conductor:	integrated	integrated

## OPERATING DATA

Cut-in wind speed:	3 m/s / 3.5 m/s	3 m/s
Rated wind speed:	11.75 m/s / 12 m/s	11.75 m/s
Cut-out wind speed:	20 m/s	20 m/s

## GENERATOR AND POWER ELECTRONICS

Generator type:	doubly-fed induction	doubly-fed induction
Rated driving power:	1650 kW	1650 kW
Cooling:	water cooling	water cooling
Converter type:	IGBT, 4-quadrant	IGBT, 4-quadrant
Generator rated power:	0.95 inductive to 0.95 capacitive at 690V ph-ph	0.95 inductive to 0.95 capacitive at 690V ph-ph

## DRIVETRAIN SPECIFICATION

Type of gearing:	planetary / parallel shaft gear	planetary / parallel shaft gear
Gear lubrication:	forced lubrication	forced lubrication
Connection gear / generator:	flexible coupling	flexible coupling

## BRAKING SYSTEM

Operational brake:	individual blade pitching	individual blade pitching
Type of construction:	gear / servomotor	gear / servomotor
Mechanical brake:	disc brake	disc brake

## YAW SYSTEM

Type of yaw bearing:	slide bearing	slide bearing
Drive unit:	gear motor	gear motor
Number of drive units:	4	4
Brake:	friction in the slide bearing plus motor brake	friction in the slide bearing plus motor brake

## AMBIENT TEMPERATURE RANGE

Normal:	During operation:	-10°C to 40°C	-10°C to 40°C
	Survival range:	-20°C to 50°C	-20°C to 50°C
Cold climate:	During operation:	-30°C to 40°C	-30°C to 40°C
	Survival range:	-40°C to 50°C	-40°C to 50°C
Hot climate:	During operation:	0°C to 50°C	0°C to 50°C
	Survival range:	-5°C to 50°C	-5°C to 50°C