

## Using Dynamic Reactive Compensation to Mitigate Voltage Sags at a Micron Technology Semiconductor Manufacturing Facility

### The Problem

Voltage sags cause major process interruptions in semiconductor manufacturing facilities (or “fabs”) around the world. The resulting loss of productivity can be very costly in terms of overall factory effectiveness. Sensitive process equipment often must be reprogrammed and restarted, work-in-process wafers may need to be scrapped, and production deadlines could be significantly extended. Electric utility supply systems are sprawling and employ numerous components, exposing the utility system to frequent service impairment problems. Wide-ranging impacts include short circuits (faults) on the utility supply system. Faults can be single phase, phase-to-phase, three-phase, or an evolving combination of all three. Large amounts of current flowing into the fault are typically drawn from many utility sources, creating a voltage drop along the fault current collection path in the utility system, and lowering the system’s voltage along the current path. Even for faults that do not cause a complete outage to an industrial load, momentary voltage sags can branch out to a large area of the utility system, affecting many industrial plants and processes in their path.

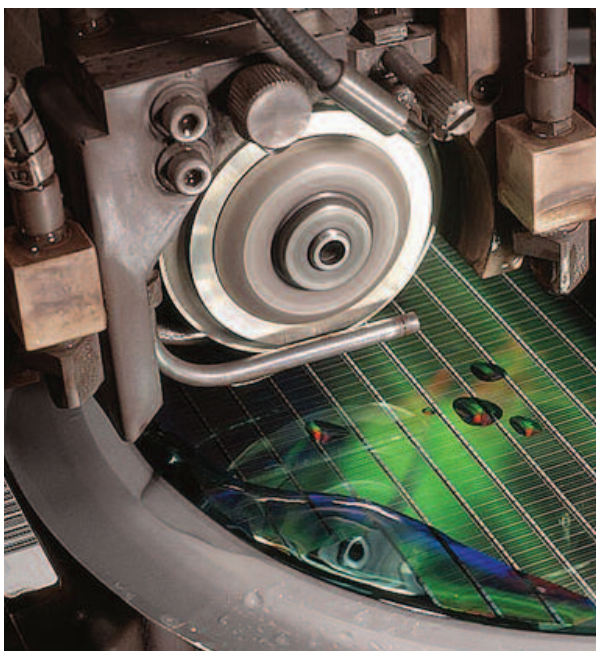

Die cutting process: One of the several hundred crucial steps in turning a wafer into a finished chip.

### The Impact of Voltage Sags at Micron

With more than \$5 billion in annual revenues, **Micron Technology, Inc.** (NYSE: MU) is one of the world’s largest producers of advanced memory and imaging semiconductor products that are used to capture, move, and store data by the world’s most successful companies. Micron had been experiencing voltage sags that typically occurred due to severe weather and breaker re-closure operations to clear faults at its Boise, Idaho facility. To quantify the negative effects of these voltage disturbances and to justify the installation of a voltage-disturbance solution, Micron collected high-speed voltage sag data for several years. The analysis of the sag data warranted the installation of a robust power solution to keep critical equipment online.

### The Solution

While many systems such as uninterruptible power supplies (UPS) have been used to directly carry small loads through a voltage sag, the American Superconductor PQ-IVR® (Power Quality Industrial Voltage Restorer) system is available to correct sags for an entire industrial plant with loads of 5MW or greater. The PQ-IVR system utilizes proprietary shunt-connected inverters to correct voltage sags and swells at the industrial load. In October 2004, Micron installed an American Superconductor PQ-IVR solution for voltage sag protection at its Idaho facility. ECI, Inc. a strategic



The PQ-IVR device instantaneously injects precise amounts of reactive power into a network.

partner of AMSC® based out of Billings, Montana, provided all of the associated site engineering work required for the installation of the system.

This solution met Micron's criteria and ensured protection against voltage disturbances experienced during previous years. The Figure below shows a one-line diagram of the PQ-IVR solution for one of the feeders. The shunt-connected (not an in-line connected device) PQ-IVR provided maximum reliability for the facility. The PQ-IVR solution was identical for all four feeders.

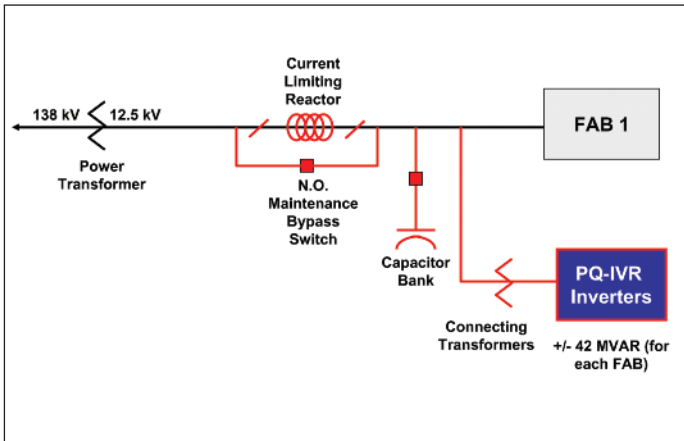

## The Results

Since installation of the PQ-IVR voltage rebuild solution in 2004, all voltage sags and swells have been properly mitigated by the PQ-IVR. Because of the robust and efficient design of the PQ-IVR system, required maintenance has been very minimal and is actually being performed by Micron themselves.

*The mitigation of voltage disturbances has resulted in a fast payback of the PQ-IVR solution.*

*"Since the installation of American Superconductor's PQ-I VR® system, it has operated as expected and corrected the sags on all of our protected feeders. We are very pleased with the customer support and the performance of the PQ-IVR systems."*

— Jack Frans, Micron Technology, Inc.

## Conclusion

With millions of dollars of work in progress and hundreds of millions of dollars of process equipment on the manufacturing floor, momentary voltage sags can quickly bring production to a standstill. American Superconductor offers semiconductor manufacturers and other industrial companies a low-cost and effective solution with a rapid return on investment. PQ-IVR systems ensure that manufacturing operations continue uninterrupted. PQ-IVR systems can correct single-, two- and three-phase sags for the largest of loads and continue to provide the same effectiveness even if loads increase over time.



Boise Campus: Micron's corporate headquarters and first semiconductor manufacturing facility is located in Boise, Idaho. Beginning as a four-man semiconductor design company in 1978, Micron is now an international, multi-billion-dollar operation.



### Sales Contacts:

8401 Murphy Drive  
Middleton, WI 53562 USA  
ph +1 608 828 9103  
fx +1 608 831 5793  
www.amsc.com

Industriering Ost 66  
47906 Kempen/Germany  
ph +49 2152 8909421  
fx +49 2152 8909422

Penthouse Level  
Suntec Tower Three  
8 Temasek Boulevard  
Singapore 038988  
ph +65 68863 629  
fx +65 68863 636