



D-SMES™

Distributed-Superconducting Magnetic Energy Storage System

- Protects transmission systems from instability, collapse and increases power transfer
- Provides real and reactive power injection
- Utilizes proprietary, four quadrant, IGBT Inverters
- Works in combination with capacitors and other FACTS devices

WPS Carryover Event 9/1/00

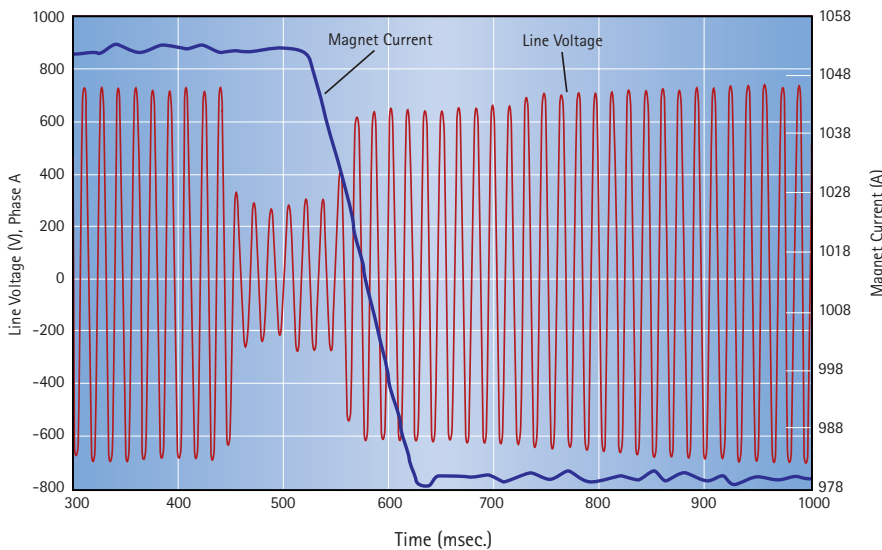

Chart of the September 1, 2001 event, with Phase C line voltage in red and magnet current in blue. The four quadrant, IGBT inverters responded with 7 MVAR output within four cycles of the fault's start. When voltage did not recover to 0.75 p.u. within two more cycles, real power stored in the D-SMES unit was discharged. This real power injection was instrumental in bringing voltage to 0.9 p.u. within two more cycles, meeting WPS specifications. Less than half a second after the disturbance, the grid had returned to nominal voltage.

FEATURES & BENEFITS

Superconducting Magnetic Energy Storage
Provides real and reactive power with a sub-cycle response time. Connected in shunt

Instantaneous Real Power (3 MW) (Optional)
Prevents voltage collapse, voltage instability and increases power transfer

Variable Dynamic VAR Injection
Supports power flow and voltage recovery on transmission systems

Independent of Load Level
Supports systems of any capacity

Proven Design
Over 50 site years of field experience

Trailerized Installation
Allows fast start-up and easy system mobility to meet changing needs

High System Efficiency
Extremely low system losses

Monitoring and Alarm System
24x7 system performance and diagnostic monitoring

Environmentally Benign
No special permitting required

Power Flow and Stability Studies
Our staff of transmission planning engineers can assist in stability studies

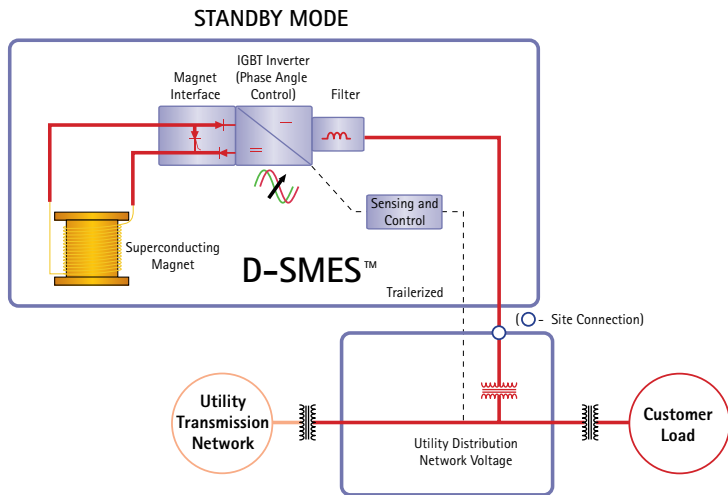

D-SMES is a shunt connected Flexible AC Transmission (FACTS) device designed to increase grid stability, improve power transfer, and increase reliability. Unlike other FACTS devices, D-SMES injects real power as well as dynamic reactive power to more quickly compensate for disturbances on the utility grid. Fast response time prevents motor stalling, the principal cause of voltage collapse.

AMSC's proprietary inverter design is based on the Power Electronic Building Block (PEBB) concept. Each trailer contains four quadrant, IGBT inverters rated at 250 kW and stacked to handle the output demands of the system. The inverters provide up to 2.3 times nominal instantaneous over-current capability and can also be configured for continuous VAR support. Each 250 kW building block operates independently, improving reliability.

D-SMES combines two of American Superconductor's core technologies, superconducting magnetic energy storage (SMES) (optional) and power electronics. Each unit stores up to 3 MJ of energy with virtually limitless charge/discharge cycles.

D-SMES features a proven design with a track record of reliable performance. It offers continuous reactive compensation capabilities as well as instantaneous real power injection to relieve transmission level voltage disturbances and increase power transfer capability. D-SMES is an attractive option for utilities with voltage instability or transfer limitations.

Through an alliance with GE, American Superconductor offers a variety of financing options. Whether you want to buy or lease, GE/American Superconductor can tailor a system to meet your financial and system needs.

D-SMES™ SPECIFICATIONS

Power Ratings

Trans. Grid volts:	69-500 kV
Frequency:	50 or 60 Hz
Grid Capacity:	Customized, based on system study
Reactive Power:	Up to 8 MVAR continuous Up to 18.4 MVAR instantaneous, 2.3 times inverter rating, instantaneous, reactive
Response Time:	Subcycle

Power Electronics

Inverter:	IGBT, 4-quadrant
Rating:	1 MVAR continuous per stack, 2.3 times instantaneous over-current capacity
Output:	480V, combined 3 ϕ control (independent 1 ϕ control available)

Magnet Data

Power Discharge:	3 MW
Energy Storage:	3 MJ
Recharge Time:	<90 seconds

Cryostat (included with magnet option)

Heat Loss Budget:	~1 Watt
Containment:	304 SS, ASME Sec VII, Div. 1, 1997 pressure vessel, triple relief vent system
Reserve Time:	5 day minimum with unit in operation

Monitor

Control Monitor:	Subcycle monitoring of utility voltage
System Monitor:	24 data and alarm signals, modem output

Installation Dimensions and Configuration

Trailer Size:	DOT approved 53' or 61' (18.6m) trailer, ~65,000 lbs (29,500 kg)
Field Strength:	5 Gauss at 17' (6.1m) from magnet, per ACGIH minimum



GE Industrial Systems

381 Broadway
Fort Edward, NY 12828-1000
Ph: 518.746.5243
Fax: 518.746.5226
Web site: www.geindustrial.com

AMSC-PQR-DEA-278



American Superconductor

2114 Eagle Drive
Middleton, WI 53562-2550
Ph: 608.831.5773
Fax: 608.831.5793
Web site: www.amsuper.com

©2001 American Superconductor

American Superconductor Europe GmbH
Rathausstraße 7
41564 Kaarst, Germany
Ph: 49.2131.766051
Fax: 49.2131.668734

ASC/P DS005-01 June 2001