



What if one device could solve...

PV
Capacity

+

CVR
Control

+

Power
Quality

+

Volt
VAR

15kV Dynamic Volt/VAR Compensator

Over the last several years, there has been a rapid rise in Distributed Energy Resources (DER), in particular distributed generation from PV in forms of residential rooftop, small utility scale and commercial solar installations. Because renewable energy is dynamic and intermittently variable in nature, distribution grids must now enhance their network's capabilities to accommodate this new resource, while maintaining efficiency and superior power quality for their customers. D-VAR VVO™ solutions offer precise and fast reactive power control to maintain utility standards while enabling exponentially growing interest in distributed generation.

A Powerful New Tool

Featuring continuous control of reactive current, these power electronic compensators can be used to solve dynamic response limitations and costly mechanical wear issues associated with conventional switched cap banks and tap changing regulators. System benefits include increased feeder hosting capacity of distributed generation and reduction of voltage flicker and harmonics in distribution circuits.



Build and designed upon proven experience

- 15kV distribution class shunt compensation solution
- Operates by injecting a controlled amount of reactive current (inductive or capacitive)
- Autonomous or dispatched control modes
- Three phase or single phase operation

Easy to Install

- Installation requirements similar to voltage regulators
- No routine maintenance
- Can be installed along feeders or in substations

D-VAR VVO™

Single Phase Power Electronic Unit

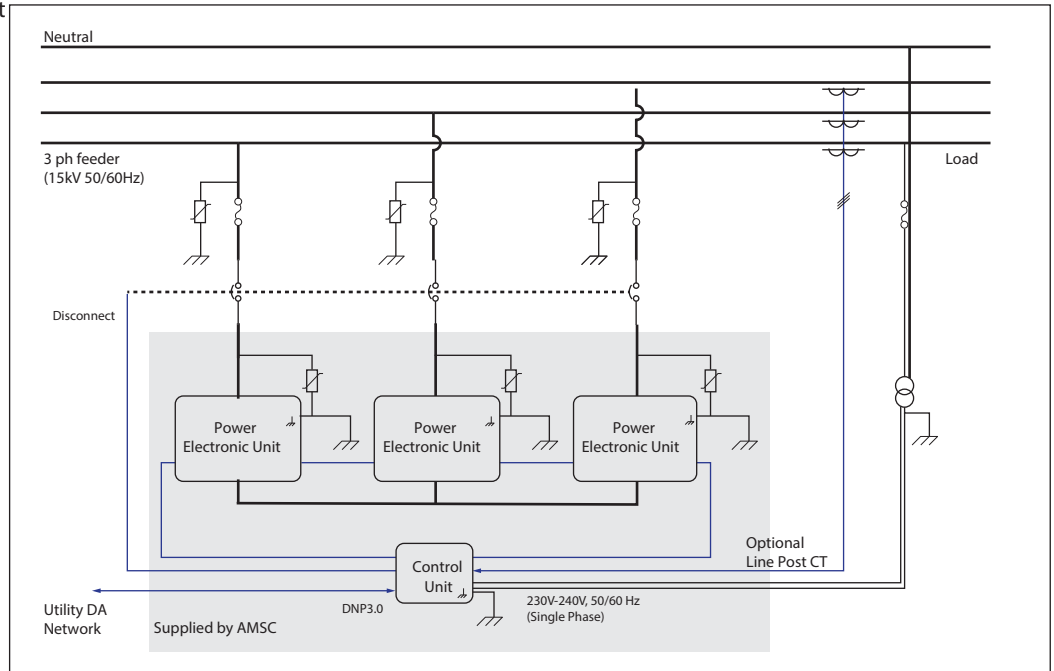
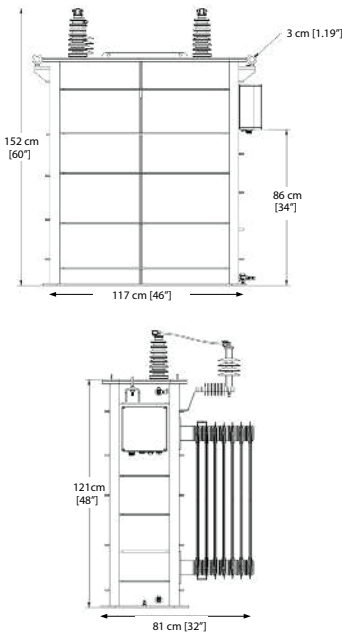

ELECTRICAL	
Connections	three phase floating wye, three phase grounded wye, single phase line to neutral
Installation locations	Along feeder or in substation
Connection voltage	Up to 13.8 kV direct connection (no transformer required)
Operating range (voltage)	0.5 pu - 1.25 pu (@ 12.47kV Line-Line)
System frequency	50/60 Hz
Nominal kVAR Rating (+/-)	1 MVAR 3ph (@ 12.47 kV Line-Line) 333 kVAR 1ph (@ 7.2 kV Line-Neutral)
Overload Rating (temporary)	1.3x for 1 minute
Harmonics	< 3.5% THD (IEEE-519 compliant)
Rated losses	1% of output, typical
Standby losses	< 1.6 kW switch closed, zero current injected
EQUIPMENT	
Temperature range (1)	-40 to +45 deg C (-40 to +113 deg F)
Altitude	1000 meters (3280 ft) (derating applies above)
BIL Rating	95 KV
Enclosure	Sealed tank, corrosion resistant ANSI C57.12.28
Approx. Dimensions (single pole mount module)	152 x 81 x 117 cm (60" x 32" x 46") H x W x D includes bushings & radiators
Approximate weight (pole mount module)	< 1100 kG (2500Lbs)
Pad mount module	contact factory
(1) applies for outdoor environment	

CONTROL	
Autonomous	Volt/VAR, Feeder VAR, or Feeder Power Factor
Dispatchable set points	Voltage, Feeder VARs, Feeder Power Factor set point
Disconnect	External vacuum switch
SCADA Connection	DNP 3.0 over Ethernet
Wireless remote monitoring	DIN rail slot for cell modem
Other controls	Independent phase control
CUSTOMER I/O	
Control Supply	230-240Vac input, single phase (50/60Hz), replaceable inline fuse
Control Power Transformer	3 kVA (min), 10 kVA (max)
Dry Contact Outputs	2 contacts, Up to 230Vac, 6Arms (also rated for 48Vdc)
Digital Inputs	2 inputs (wetted by AMSC control, 12-48Vdc)
CT Inputs	600A: 10V (gland cable entry)
Grounding Stud	Screw terminal, supports 2/0 to 8 AWG
Other	AMSC control connector kit specified separately
SCADA Protocol	DNP 3.0 (AMSC to provide points database)
SCADA Physical Layer	RJ45, Ethernet, 10/100
Wireless Radio Supply	12Vdc, 1A (other options available)
Wireless Radio Interface	see SCADA physical layers
Dedicated Service Port	USB